

REED



Model SD-4307

Data Logging Conductivity/
TDS/Salinity Meter

Instruction Manual



REED Instruments

1-877-849-2127 | info@reedinstruments.com | www.reedinstruments.com

Table of Contents

Features.....	3
Specifications.....	4-5
Instrument Description	6
Operating Instructions.....	7-11
<i>Function selection</i>	7
<i>Conductivity Measurement</i>	7
<i>Changing the Air velocity unit</i>	7
<i>Manual Range</i>	7
<i>Zero Adjustment</i>	8
<i>TDS Measurement</i>	8
<i>Salt Measurement</i>	8
<i>Calibration</i>	8-9
<i>Data Record (Max., Min. reading)</i>	9
<i>Backlight ON/OFF</i>	10
<i>Datalogger</i>	10
<i>Auto Datalogger</i>	10-11
<i>Manual Datalogger</i>	11
<i>Checking the Time</i>	11
<i>Check Sampling Time Information</i>	11
<i>SD Card Data Structure</i>	12
<i>Data Transfer from SD card to Computer</i>	12
Advanced Settings	13-15
<i>Set Clock Time</i>	12
<i>Setting the Decimal point on the SD Card</i>	13
<i>Auto power OFF management</i>	13
<i>Set Beeper Sound ON/OFF</i>	13
<i>Select the Temperature unit to °C or °F</i>	13
<i>Set sampling time</i>	14
<i>SD memory card Format</i>	14
<i>Setting the CD Temperature Compensation Factor</i>	15
<i>ESC</i>	15
PC Serial Interface.....	16
System Reset	17
Battery Replacement.....	17

Features

- Multi-purpose meter, measuring Conductivity, TDS (Total dissolved solids), and Salt
- Conductivity: 200 μ S/cm, 2mS/cm, 20mS/cm, 200mS/cm
- Salt: 0 to 12% salt (% weight)
- Conductivity measurement can select Temp. Coefficient of Measurement Solution
- Real time SD memory card datalogger with a built-in clock and calendar
- Sampling time set from 1 second to 9 hours
- Meter can switch to a Manual Datalogging
- No extra software needed, just plug the SD card into the computer and it downloads directly to EXCEL
- SD card capacity: 1 GB to 16 GB
- Easy to read LCD with backlight
- Auto power off or manual power off
- Data hold, record max. and min. reading
- High accuracy microcomputer circuit
- Power by UM3/AA (1.5 V) x 6 batteries
- USB/RS232 Computer interface
- Separated probe for easy measurements of multiple environments

Specifications

Circuit:	Custom microprocessor LSI circuit
Display:	52 x 38 mm LCD with backlight
Conductivity Units:	μS, mS
TDS Units:	PPM
Salt Units:	% (of weight)
Conductivity Probe:	Carbon rod electrode
Auto Sampling Time:	1 second to 9 hours
Memory Card:	SD memory card, 1 GB to 16 GB
Sampling Time of Display:	Approx. 1 second
Data Output:	USB/RS232 PC computer interface
Temperature Range:	0-50°C (0-122°F)
Resolution:	0.1°C/0.1°F
Accuracy:	±0.8°C/1.5°F
Operating Temperature:	Meter: 0 to 50°C; Probe: 0 to 60°C
Operating Humidity:	Less than 85% R.H.
Power Supply:	UM3/AA (1.5 V) x 6 batteries
Weight:	515 g/1.13 lb
Dimensions:	Meter: 177 x 68 x 45 mm (7.0 x 2.7 x 1.9") Probe: 22 x 120 mm
Includes:	Conductivity/TDS/Salt Probe and a Hard Carrying Case
Optional accessories:	4G SD Card (SD-4GB) USB Cable (USB-01) Power Adapter (AP-9VA-110V) Data Acquisition Software (SW-U801-WIN) Tripod (BS-6)

Conductivity Specifications

Range	Measurement	Resolution	Accuracy
200 μ S/cm	0 - 200 μ S/cm	0.1 μ S	±(2% Full Scale +1d) at 23 ± 5°C
2mS/cm	0.2 – 2mS/cm	0.001mS	
20mS/cm	2 – 20mS/cm	0.01mS	
200mS/cm	20 – 200mS/cm	0.1mS	

TDS Specifications

Range	Measurement	Resolution	Accuracy
200PPM	0 -132PPM	0.1 PPM	±(2% Full Scale +1d) at 23 ± 5°C
2,000PPM	132 - 1,320PPM	1PPM	
20,000PPM	1,320 - 13,200PPM	10PPM	
200,000PPM	13,200 - 132,000PPM	100PPM	

Salt Specifications

Measurement Range: 0 to 12% Salt (% weight)

Resolution: 0.01% Salt

Accuracy: 0.5% Salt value

Instrument Description

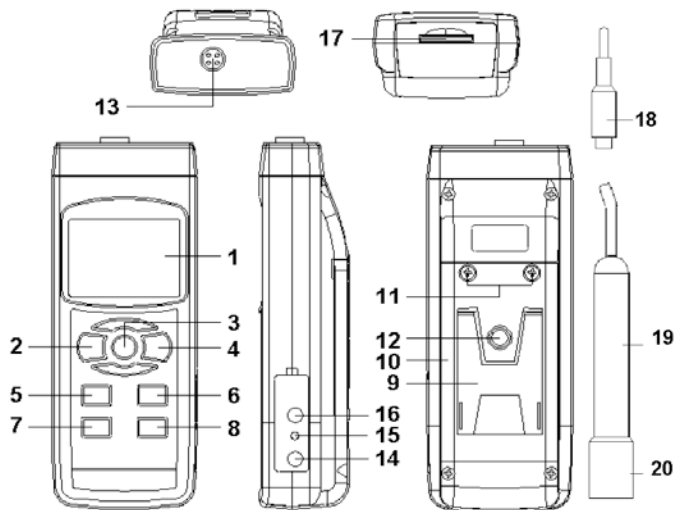

- | | |
|--|---|
| 1. Display | 11. Battery Cover Screw |
| 2. Power & Backlight Button | 12. Tripod Fix Nut |
| 3. Hold & ESC Button | 13. Probe Socket |
| 4. REC & Enter | 14. AC/DC 9V Power Adapter Input Socket |
| 5. Mode & Up Button | 15. Reset Button |
| 6. Range & Down Button | 16. USB/RS232 Output |
| 7. Time Button | 17. SD Card Slot |
| 8. Logger, SET & Sampling Check Button | 18. Probe Plug |
| 9. Stand | 19. Probe Handle |
| 10. Battery Compartment | 20. Probe Sensor |

REED Instruments

1-877-849-2127 | info@reedinstruments.com | www.reedinstruments.com

Operating Instructions

Function selection

- 1) Turn on the meter by pressing the Power Button. To turn the meter off, hold the Power Button for over 2 seconds.
- 2) The meter has 3 measuring functions to choose from: Conductivity, TDS, and Salt.

When the meter is on, press and hold the Mode Button. The display will flash "Cd", for Conductivity measurements, "tdS" for TDS measurements, and "SALT" for Salt measurements. Release the Mode Button to choose the displayed function. The meter's defaults are following:

Display Unit:	Conductivity
Temperature Unit:	°C
Temp. Compensation Factor:	2.0% per °C
Auto range:	ON
Auto power off:	ON
Datalogger Sampling Time:	2 seconds

Conductivity Measurement

- 1) When the meter is off, plug the Probe Plug into the Probe Socket, then power on the meter by pressing the Power Button.
- 2) Select the "Cd" function (see Function Select).
- 3) Hold the Probe Handle and fully immerse the Probe Sensor into the measuring solution. Shake the Probe to let the Probe's internal air bubble drift out from under the sensing head. The top part of the Display will show the conductivity mS (µS) values, and the lower part of the Display will show the temperature value of the solution.

Manual Range

The meter is defaulted to Auto Range mode. Push the Range Button to change the range from 200µS/cm, 2mS/cm, 20mS/cm, 200mS/cm and Auto Range.

Zero Adjustment

If the probe is not immersed in the measuring solution and the display will not show a Zero Value. Press and hold the Up Button for about 10 seconds and the display will then show zero. The Zero function is only valid for the 200 μ S range and not when the Zero Value is < 2.0 μ S.

TDS Measurement

- 1) When the meter is off, plug the Probe Plug into the Probe Socket, then power on the meter by pressing the Power Button.
- 2) Select the "tdS" function (see Function Select)
- 3) Hold the Probe Handle and fully immerse the Probe Sensor into the measuring solution. Shake the Probe to let the Probe's internal air bubble drift out from under the sensing head. The Display will show the Total Dissolved Solids value.

Salt Measurement

- 1) When the meter is off, plug the Probe Plug into the Probe Socket, then power on the meter by pressing the Power Button.
- 2) Select the "SALT" function (see Function Select)
- 3) Hold the Probe Handle and fully immerse the Probe Sensor into the measuring solution. Shake the Probe to let the Probe's internal air bubble drift out from under the sensing head. The Display will show the Salt value (% of weight).

Calibration

- 1) Prepare the optional standard conductivity solution
- 2) Install the Probe Plug into the Probe Socket
- 3) Power on the meter by pressing Power Button
- 4) Hold the Probe Handle and let the Sensing head get fully immersed the calibration solution. Shake the probe to let the probe's internal air bubble drift out from the sensing head. The display will show the conductivity values.

continued...

- 5) Press the REC Button and HOLD Button at the same time. The display will show the symbol "Cd" and "CAL"
- 6) Press the Enter Button and the measuring value will show on both the upper and lower Display. Use the Up and Down Buttons to adjust the upper display value to be the exact same as the standard conductivity value. Press the Enter Button to save the calibration data and finish the calibration procedures.

NOTE: If you only intend to make a one point calibration, executing the 2mS/cm range (1.413mS Cal.) is enough. Multi-point calibration procedures should execute the 2mS/cm range (1.413mS Cal.) calibration at first, then make other ranges (2mS/cm, 20mS/cm, 200mS/cm) after if necessary.

Data Record (Max., Min. reading)

The data record function records the maximum and minimum readings. Press the REC Button once to start the Data Record function and a "REC" symbol will appear on the display. With the "REC" symbol on the display:

- 1) Press the REC Button once, and a "REC. MAX." symbol along with the maximum value will appear on the display. To delete the maximum value, press the Hold Button once and the display will show a "REC." symbol only and execute the memory function continuously.
- 2) Press the REC Button again, and a "REC. MIN." symbol along with the minimum value will appear on the display. To delete the minimum value, press the Hold Button once, and the display will show a "REC." symbol only and execute the memory function continuously.
- 3) To exit the memory record function, press the REC button for 2 seconds. The display will revert to the current reading.

Backlight ON/OFF

After powering the meter ON, the LCD Backlight will turn on automatically. While taking measurements, press the Backlight Button and the LCD Backlight will turn off. Press the Backlight Button once again to turn the LCD Backlight back ON.

Datalogger

Preparation Before Executing the Datalogger Function:

- 1) Insert the optional SD card into the SD card socket.
- 2) Before you use an SD card with this meter for the first time, it is recommend to format the SD card. See Advanced Settings section of this manual for instructions.
- 3) If this is the first time the meter is used you need to adjust the clock. See Advanced Settings section of this manual for instructions.
- 4) Now you need to set the decimal format. The numerical data structure downloaded to the SD card is defaulted used the "." as the decimal, for example "20.6" "1000.53". But in certain countries the "," is used as the decimal point, for example "20,6" "1000,53". See Advanced Settings section of this manual for instructions on how to change the Decimal Character.

Auto Datalogger (Set sampling time ≥ 1 second)

- 1) Start Datalogging; press the REC Button, and the "REC" symbol will appear on the LCD screen, then press the Logger Button, the "REC" symbol will flash while the measuring data and time information is being saved in memory. To set the sampling time, and to toggle the beeper sound on or off, refer to the Advanced Settings section of this manual.
- 2) Pause the Datalogging; while Datalogging, if press the Logger Button once. While paused, the "REC" symbol will stop flashing. Press the Logger Button again to resume Datalogging, and the "REC" symbol will begin to flash again.

continued...

- 3) Stop Datalogging; while the Datalogger function is paused, press the REC Button for 2 seconds. The "REC" symbol will disappear indicating the Datalogging function has stopped.

Manual Datalogger (Set sampling time = 0 seconds)

- 1) Set sampling time is to 0 second; Press the REC Button, and the "REC" symbol will appear on the LCD screen. Press the Logger Button, and the "REC" symbol will flash once and one Beep will sound, at the same time the measuring data along the time information will be saved in memory. The lower Display will show the Position (record) number, which is saved as well.
- 2) To Change the Position Number; press the Down Button and the lower position number will flash on the display. Press the Up or Down Buttons to set the Position Number (1 to 99) to help identify the measurement location. The lower Display will show P x (x = 1 to 99). After the position number is selected, press the Enter Button to confirm.
- 3) Stop Datalogging; press the REC Button for 2 seconds, and the "REC" symbol will disappear indicating the Datalogging function has stopped.

Checking the Time

During normal functions (not Datalogging), press the Time Check Button and the lower LCD display will show the Year, Month/Date, Hour/Minute.

Check Sampling Time Information

During normal functions (not Datalogging), press the Sampling Button and the lower LCD display will show the Sampling Time Information.

SD Card Data Structure

- 1) The first time the SD card is used in the meter, the SD card will generate a folder: CDA01
- 2) The first time you use the Datalogger, in the folder CDA01, a new file name CDA01001.XLS will be created. The Datalogger will use this file until the Data has reached to 30,000 rows. The meter will then will generate a new file with a subsequent number, for example CDA01002.XLS.
- 3) The folder CDA01 can hold 99.XLS files. When that number has been reached, the meter will then will generate a new folder with a subsequent number, for example CDA02. Max number of CDA-- folders is 10.

Data Transfer from SD card to Computer (EXCEL Software)

- 1) After Datalogging, remove the SD card from the SD card slot.
- 2) Plug in the SD card into the Computer's SD card slot or insert the SD card into the optional SD card adapter and connect to your Computer. Turn your computer on and a folder will appear on your desktop representing you SD card.
- 3) Open "Microsoft EXCEL". Download the EXCEL files from the SD Card to the computer by opening up the SD folder and selecting the desired EXCEL files, and drag-and-drop them onto your Computer. Open the files with EXCEL (File – Open).
- 4) The EXCEL file will have the following column headers in this order: Place (Position Number), Date (Year/Month/Day), Time (in 24h clock), Value & Unit.

Advanced Settings

During normal functions (not Datalogging), press and hold the SET Button for 2 seconds to enter the "Advanced Setting" mode. Press the Next Button scroll through eight main functions, shown on the lower display:

dAtE Set clock time (Year/Month/Date, Hour/Minute/Second)

dEC Set SD card Decimal character

PoFF Auto power OFF management

bBEEP Set beeper sound ON/OFF

t-CF Select the temperature unit to °C or °F

SP-t Set sampling time (Hour/Minute/Second)

Sd F SD memory card Format

PEr C Set CD temperature compensation factor

ESC Exit Advanced Settings

While in the "Advanced Setting" function, press the Esc Button to exit and to return to normal functioning.

Set Clock Time

- 1) When the lower display shows "dAtE", press the Enter Button. Use the Up and Down Buttons to adjust the Year. After the desired value is set, press the Enter Button to adjust the Month, Date, Hour, Minute, and Second values.
- 2) After all the time values have been set the screen will jump to "SD card Decimal character" setting screen. To exit "Advanced Settings", press the Esc Button.

Note: After the time value is set, the internal clock will run even when the power is off, if the battery is under normal conditions.

Setting the Decimal point on the SD Card

- 1) When the lower display shows "dEC", use the Up or Down Buttons to toggle between "bASIC" ("." Decimal Point) or "Euro" ("," Decimal Point).
- 2) After the Decimal point character has been selected, press the Enter Button to save the setting as the default. To exit "Advanced Settings", press the Esc Button.

Auto power OFF management

- 1) When the lower display shows "PoFF", use the Up or Down Buttons to select the value "yES" (Enable Auto Power Off) or "no" (Disable Auto Power Off).
- 2) After selecting "yES" or "no", press the Enter Button to save the setting as the default. To exit "Advanced Settings", press the Esc Button.

Set Beeper Sound ON/OFF

- 1) When the lower display shows "bEEP", use the Up or Down Buttons to select "yES" (Beeper Sound is ON) or "no" (Beeper Sound is OFF).
- 2) After selecting "yES" or "no", press the Enter Button to save the setting as the default. To exit "Advanced Settings", press the Esc Button.

Select the Temperature unit to °C or °F

- 1) When the lower display shows "t-CF", use the Up or Down Buttons to select "C" (for °C) or "F" (for °F).
- 2) After selecting "C" or "F", press the Enter Button to save the setting as the default. To exit "Advanced Settings", press the Esc Button.

Set sampling time

- 1) When the lower display shows "SP-t", use the Up or Down Buttons to adjust the value.
- 2) After the Sampling value is selected, press the press the Enter Button to save the setting as the default. To exit "Advanced Settings", press the Esc Button.

SD memory card Format

Please Note: Formatting the SD card erases all data from that SD card.

- 1) When the lower display shows "Sd F", use the Up or Down Buttons to select "yES" (format the SD card) or "no" (do not format the SD card).
- 2) To format your SD card, select "yES" and press the Enter Button. The Display will show "yES Enter", to confirm. Press the Enter Button to confirm.

Setting the CD Temperature Compensation Factor

- 1) This function is only for the Conductivity (TDS) Mode to adjust the probe's Temperature Compensation value in % per °C. The default value is 2% per °C. When the lower display shows "PEr C", use the Up or Down Buttons to select the upper value to the desired Temperature Compensation.
- 2) After setting the Temperature Compensation Factor, press the Enter Button to save. To exit "Advanced Settings", press the Esc Button.

ESC

When the lower display shows "ESC", press the Enter Button to finish the Advanced Settings procedures and return to the normal measuring screen.

PC Serial Interface

The instrument features an PC output via 3.5 mm terminal. The connector output is a 16 digit data stream which can be utilized to the user's specific application. An USB RS232 lead with the following connection will be required to link the instrument with the PC serial input.

Meter (3.5mm Jack Plug)	PC (9W "D" Connector)
Center Pin	Pin 2
Ground/Shield	Pin 5

The 16 digit data stream will be displayed in the following format:
D15 D14 D13 D12 D11 D10 D9 D8 D7 D6 D5 D4 D3 D2 D1 D0

D0	End Word
D1 to D4	Upper Display reading, D1= LSD, D4= MSB
D5 to D8	D5=? D6=? D7=? D8=?
D9	Decimal Point (DP) for display 0 = No DP, 1 = 1 DP, 2 = 2 DP, 3 = 3 DP
D10	D10 = 0
D11	D11 = 0
D12	D12 = 0
D13	D13 = 0
D14	D14 = 0
D15	Start Word

System Reset

If an error occurs, press the Reset Button with a Pin. If the Reset Button does not fix the error, please send in the unit to our Calibration Lab for repair. E-mail info@reedinstruments.com for more information.

Battery Replacement

- 1) When the left corner of LCD display shows , it is necessary to replace the battery
- 2) Loosen the screws of the Battery Cover and remove
- 3) Remove the batteries and replace with Six DC 1.5 V batteries (UM3, AA, Alkaline/heavy duty)
- 4) Make sure the battery cover is properly secured after changing the battery

For service or information on this or any other REED product, contact REED Instruments at info@reedinstruments.com.

REED Instruments

1-877-849-2127 | info@reedinstruments.com | www.reedinstruments.com

