

# Installation

## EFX 60/S19-2200

### Thermostatic Mixing Valve with Optional Cabinet

### Robinet thermostatique mélangeur avec armoire en option

### Válvula mezcladora termostática con armario opcional

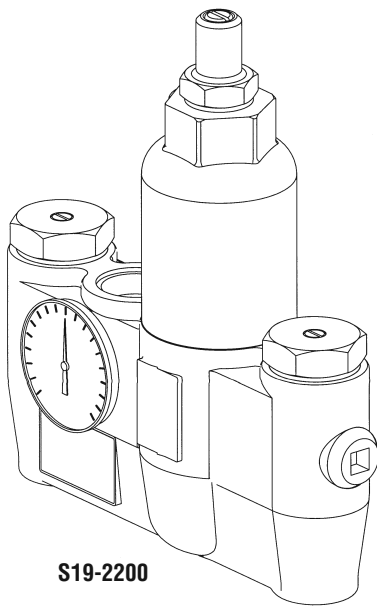

S19-2200

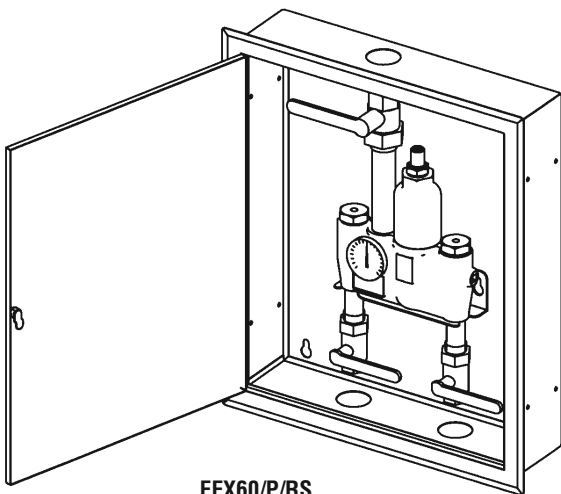

EFX60/P/RS

#### Table of Contents

Supplies Required.....	2
Installation Instructions .....	2
Dimensions .....	3
Optional Equipment Installation .....	5
Troubleshooting.....	6

#### Sommaire

Fournitures requises .....	9
Instructions relatives à l'installation.....	9
Dimensions .....	10
Installation de l'équipement optionnel.....	12
Dépannage .....	13

#### Tabla de contenidos

Materiales necesarios.....	16
Instrucciones de instalación.....	16
Dimensiones .....	17
Instalaciones de equipos opcionales .....	19
Solución de problemas .....	20

Inlet Connections: 1" NPT  
Outlet Connection: 1-1/4" NPT  
Temperature Range: 65 – 95°F  
Maximum Pressure: 125 PSI  
Inlet Temperature Hot: 120 – 180° F  
Inlet Temperature Cold: 33 – 80° F  
Minimum Temperature Differential  
(from valve set point): 20° F

Raccords d'arrivée : 1 po NPT  
Raccord de sortie : 1-1/4 po NPT  
Plage de température : 65 – 95 °F  
Pression maximum : 125 lb/po<sup>2</sup>  
Température d'arrivée, eau chaude : 120 – 180 °F  
Température d'arrivée, eau froide : 33 – 80 °F  
Différence de température minimum  
(à partir de valeur de consigne de robinet) : 20 °F

Conexiones de entrada: NPT de 1 pulg.  
Conexión de salida: NPT de 1-1/4 pulg.  
Rango de temperaturas: 65 – 95 °F  
Presión máxima: 125 PSI  
Temperatura de entrada, caliente: 120 – 180 °F  
Temperatura de entrada, fría: 33 – 80 °F  
Diferencial de temperatura mínima  
(desde el punto de ajuste de la válvula): 20 °F



## IMPORTANT!

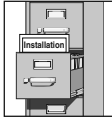

Read this entire installation manual to ensure proper installation. When finished with the installation, file this manual with the owner or maintenance department. Compliance and conformity to local codes and ordinances is the responsibility of the installer.



Separate parts from packaging and make sure all parts are accounted for before discarding packaging material. If any parts are missing, do not begin installation until you obtain the missing parts.

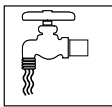

Make sure that all water supply lines have been flushed and then completely turned off before beginning installation. Debris in supply lines can cause valves to malfunction.



Product warranties may be found under "Products" on our web site at [bradleycorp.com](http://bradleycorp.com).

### Supplies recommended for installation

- Lockable shut-off on the outlet if tempered water is supplied to one or more emergency fixtures
- Lockable shut-off on the inlets/supplies
- (6) 3/8" wall anchors and fasteners for surface-mounted cabinet
- (4) 1/4" fasteners (and wall anchors, if necessary) for recess-mounted cabinet
- Unions on all connections to facilitate removal of valve

### Tools required for temperature adjustment

- 5/32" Allen wrench
- Blade screwdriver

## 1 Install Optional Cabinet (If not installing cabinet, skip to Step 2)

#### Recessed Cabinet:

1. Rough-in wall opening 24-1/2" W x 28-1/2".
2. Insert the cabinet and secure to wall with four 1/4" fasteners properly anchored (supplied by installer.)
3. Install two anchors and screws through the valve bracket in back of the cabinet into a secure brace (supplied by installer) or into wall. This will support the valve.
4. Install the valve nipples and one-half of the union ball valve using pipe sealant or teflon tape. Install the other half of the union ball valve onto inlet and outlet pipe.
5. Insert the valve into the bracket in the cabinet (right side goes in first). Continue with the valve installation procedure.
6. Position the wall flange tight to the wall and caulk in place.

#### Surface-Mounted Cabinet:

1. Measure and mark the cabinet mounting hole locations at the dimensions shown on next page. Install six 3/8" wall anchors (supplied by installer).
2. Position the cabinet onto the wall and secure into place with six 3/8" wall fasteners (supplied by installer).
3. Install the valve nipples and one-half of the union ball valve using pipe sealant or teflon tape. Then install the other half of the union ball valve onto the inlet and outlet piping.
4. Insert the valve into the bracket in the cabinet (right side of the valve goes in first). Continue with the valve installation procedure.

**Optional Recessed Cabinet**

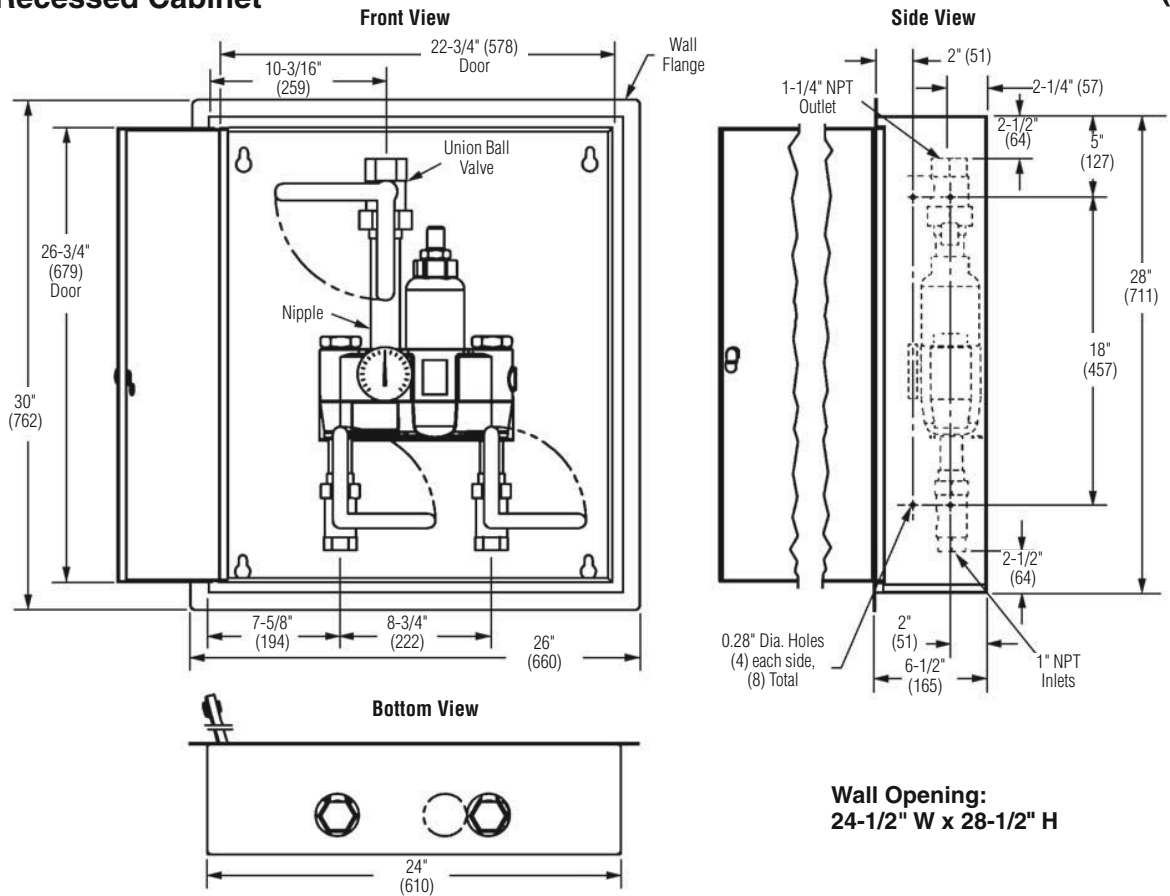

(mm)

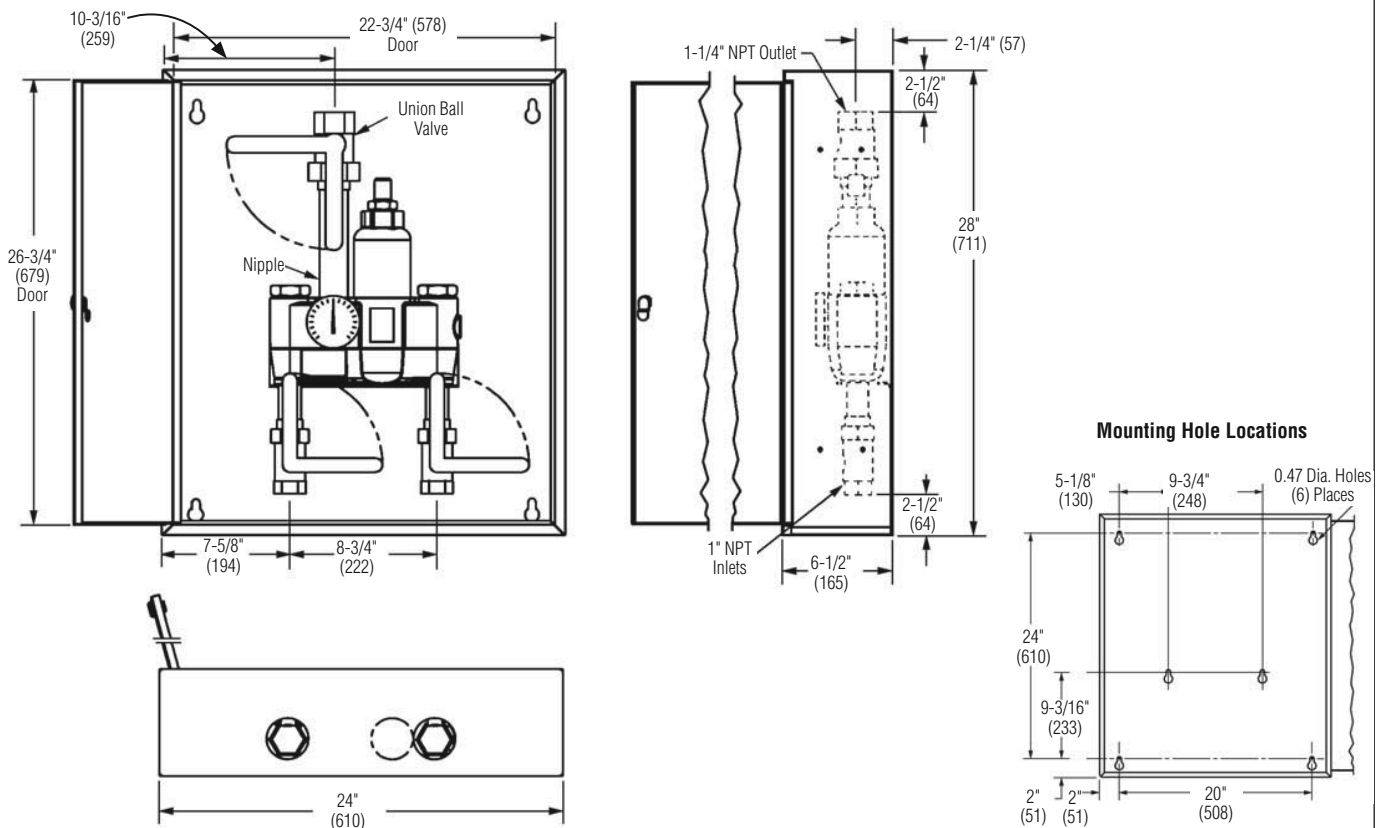

**Optional Surface-Mounted Cabinet**



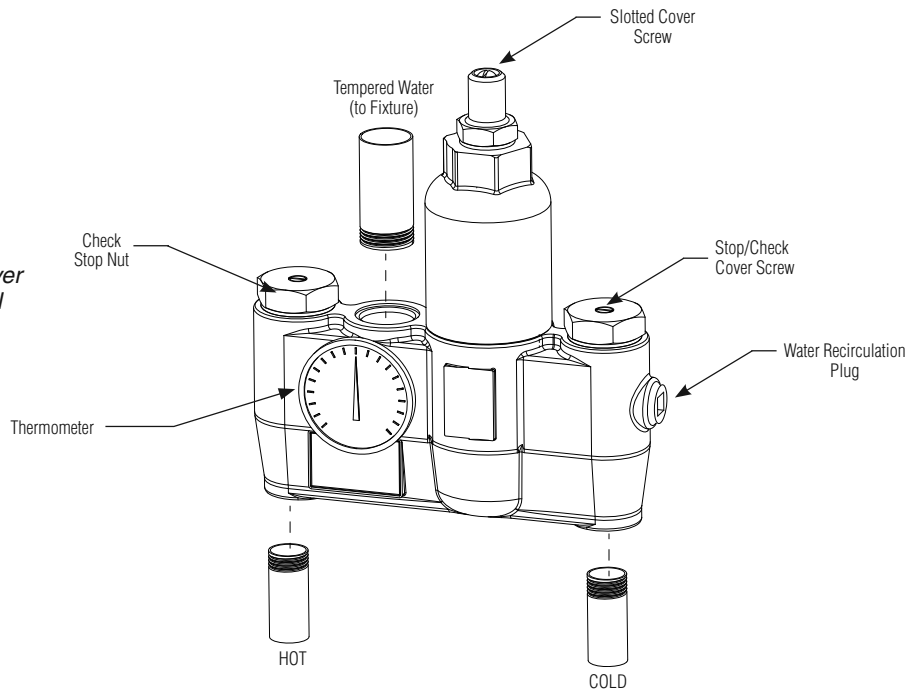

## 2 Connect Supply Lines and Install Thermometer

-  When the check valves are in the open (operating) position, the cover screw for the stop/check stem will be flush with the valve cap.
-  Install Thermometer using pipe sealant or teflon tape.
-  Check for leaks by pressurizing unit **SLOWLY**.



## 3 Adjust Temperature with Water Running

-  Check the temperature when approximately 10 GPM water flow is reached (equivalent to two face washes)
-  This device must be checked for final temperature and adjusted as necessary. The standard preset factory temperature setting is 85°F (29°C). [the range of the valve is 65°F – 95°F (18°C – 35°C)]. Consult proper medical and/or safety authorities for the optimum temperature recommended for your particular application.

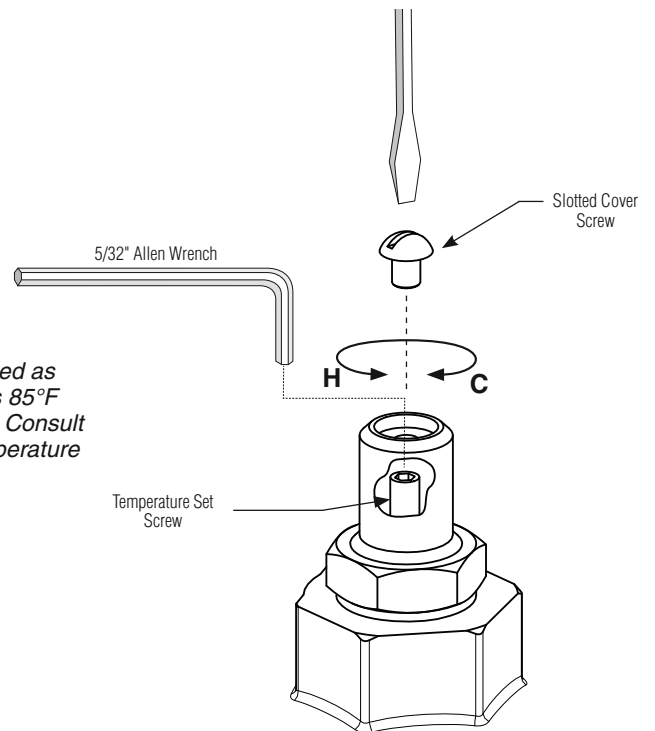

## 4 Test Unit DO NOT SKIP THIS STEP!!!

Shut the hot water supply off by closing hot water inlet valve or supply check valve. While the hot water supply is turned off, check to make sure the cold water continues to flow. If the cold water is flowing properly, reopen the hot water supply.

Shut the cold water supply off by closing the cold water inlet valve or supply check valve. While the cold water supply is off, check to make sure that the hot water flow has shut down. If hot water is shut down, reopen cold water supply. Test unit weekly for proper function and desired set temperature.

## 5 Optional Water Recirculation Setup



Recirculating the water in the system provides constant regulation of the water temperature. Flush the supply lines thoroughly after completing installation. Close off all fixtures and label them as not available for use during the recirculating process.

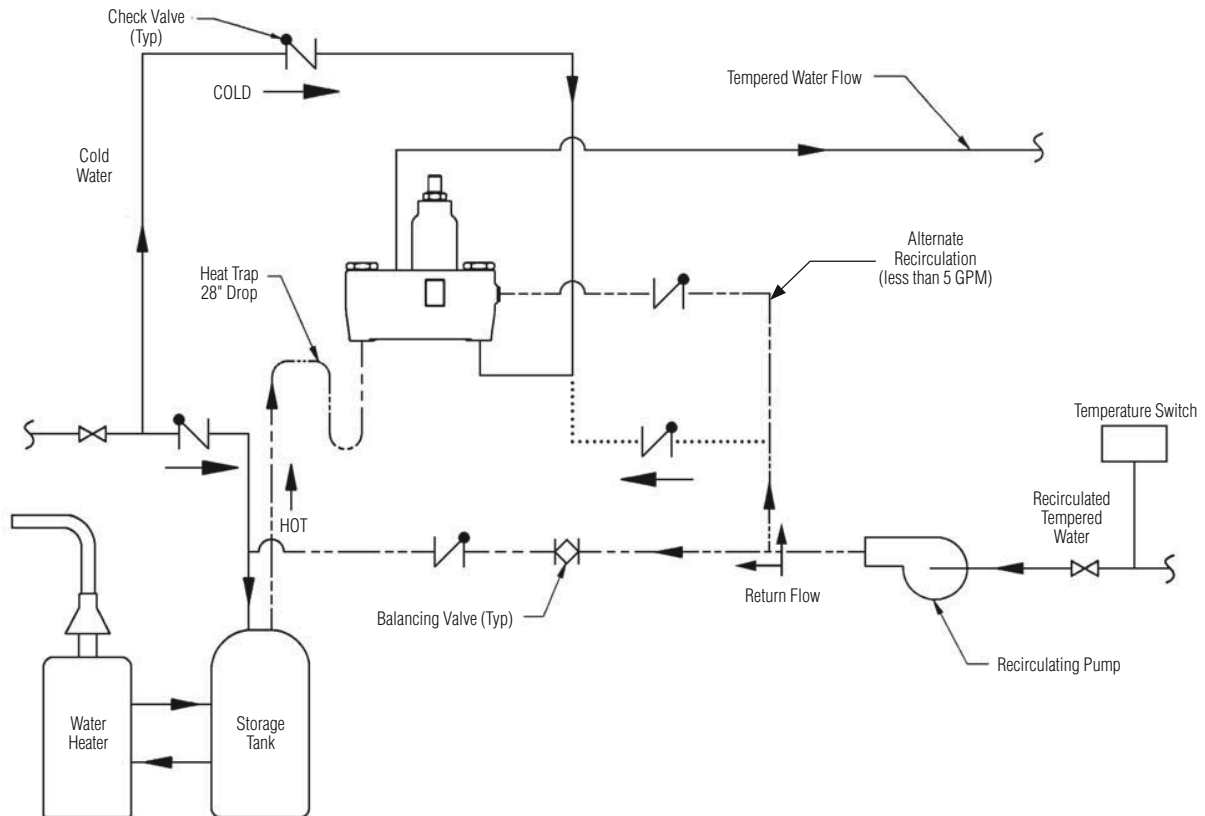

1. Turn off the recirculating pump and turn on the water supply at emergency fixture (a water flow rate of 10-15 GPM is required).
2. Let the water run through the system until a consistent temperature is obtained. If you do not obtain the required temperature, refer to step #3 on previous page for temperature readjustment.
3. As soon as the water reaches the proper temperature, turn on the recirculating pump (make certain the proper system temperature has been achieved before proceeding).
4. Check the water temperature at the return pump. If the temperature exceeds the appropriate level by 2°F, adjust the temperature high-limit switch (this will turn off the pump). Wait until the return water temperature is 5°F below the appropriate level and adjust the low-limit switch (this will turn the pump back on).
5. Open the balancing valve completely.
6. Turn off all fixtures and make sure there is no water running through the system (the cold inlet pipe should feel warm to the touch).
7. Let the system run for 30 minutes or longer without water. If, after thirty minutes, the water temperature increases, you may readjust the temperature by slowly closing the balancing valve until the appropriate temperature is reached.

### Troubleshooting Thermostatic Mixing Valve



Before attempting to troubleshoot the valve or disassemble the components, check for the following:

- Stop/check valves are fully open (the slotted stem must be flush with the stop/check cap) and that all inlet and outlet shut-off valves are open
- Hot and cold inlet pipes are connected properly, and that there are no cross-connections or leaking stop/check valves
- Water heater output is at least 15° F above the set temperature.

Be sure to close the appropriate shut-off valves prior to disassembly of the valve and reopen the valves after inspection and repair is complete.

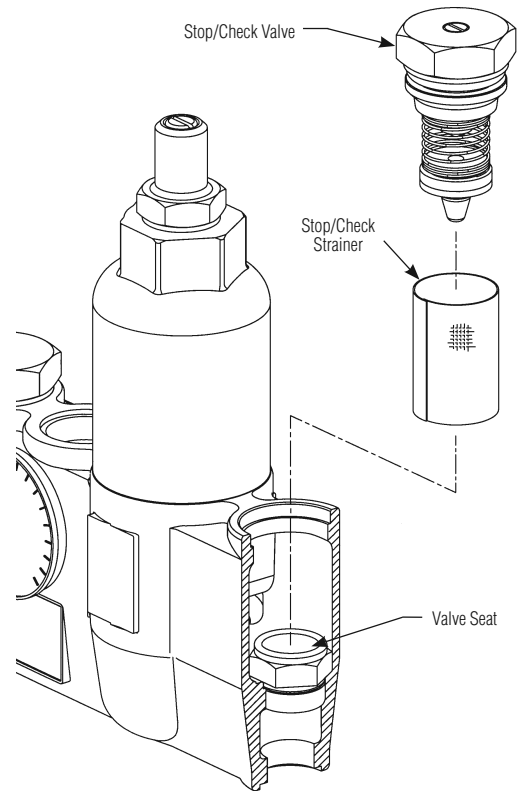

Problem	Cause	Solution
External leaks in the system	Either the NPT joints or the o-rings have been damaged.	Replace the NPT joints and/or o-rings where necessary. For replacement of o-rings, contact your Bradley representative and ask for O-Ring Seal Kit (S65-177).
No hot water flow (cold water flow only)	The thermostat has failed and, subsequently, the safety shut-off has engaged.	<b>Inspect Thermostat:</b> 1. Remove the top cap and pull out the push rod and thermostat. 2. Insert a 7/16" dia. rod into the thermostat bellows. 3. Mark the length of the thermostat bellows (at room temperature, with 10 lb. of force, the bellows length should be approx. 2-5/8"). 4. If the thermostat bellows length is not in the proper range, the thermostat must be replaced (it cannot be repaired). Contact your Bradley representative and ask for Thermostat Kit (S65-178).
Limited water flow	The inlet shut-off valve may be partially closed or there has been a significant decrease in water pressure.	<b>Clean Stop and check Valves:</b> Remove the stop and checks, clean the screen and seat and reassemble the valve. Do not remove the seat. The components may be scraped with a screwdriver to remove debris. A pair of tweezers works well for pulling debris out from the seat. If the stop and checks need to be replaced, contact your Bradley representative and ask for Check/Stop Kit (S65-179).
	Dirt and debris have collected on the check screen or seat, limiting the movement of the stop and checks.	
Temperature fluctuation or improper Temperature	The stop and check sections of the valve do not move freely.	Clean Stop and Check Valves as described above.
	Thermostat is slowly failing.	Check Thermostat as described above, or replace.
	Inlet supply line to the mixing valve is being shared by other pieces of equipment that are used only periodically, such as laundry appliances or washdown stations. It may reduce the inlet pressure to the mixing valve to less than 10 PSI. The supply line size may not be large enough to supply both the valve and the other appliances.	Enlarge the supply line size, reconfigure the supply line or regulate the supply usage.
	Recirculation is not balanced.	Review recirculation set up on page 5.
	Piston does not move freely and must be cleaned.	See next page for piston disassembly and cleaning directions.

### Troubleshooting: Piston Disassembly and Cleaning



To prevent injuries, use proper protective equipment for eyes and skin when using a propane torch.

**A**

Remove the valve's top cap and pull out the push rod and then the thermostat. You may use a needle-nose pliers to remove the thermostat from the valve body if desired.

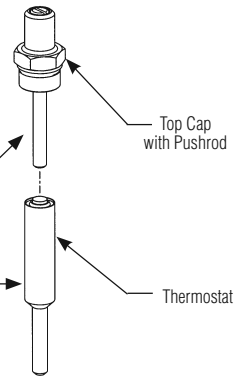

**B**

Insert a 7/16" dia. rod into the valve and into the piston overheating chamber. Mark the length of the rod inside the valve. Push the rod until the piston stops and mark the new length.

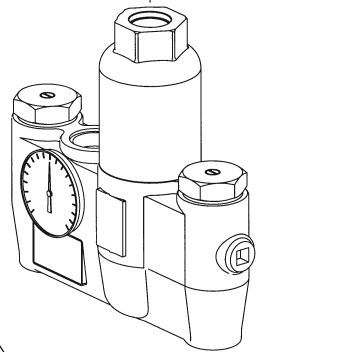

**C**

If the rod travels less than 1/2", the piston is not moving freely within the liner and they must be cleaned:

1. Remove the control section assembly, top cap and thermostat.
2. Unthread the liner from the cap (it is glued together; the o-rings must be removed and heat should be applied to melt the glue and loosen the liner).
3. Clean the piston and liner with any cleaner suitable for brass and stainless steel (400-grit sandpaper may be used to polish and hone the piston and liner).

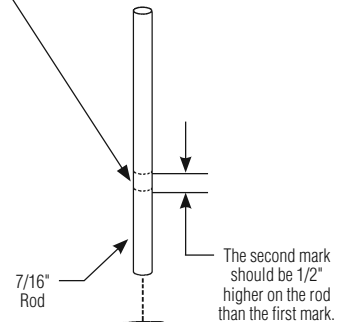

**D**

Push the mechanism up and down several times to make sure the piston moves smoothly and consistently. If it is not consistent, repeat Procedure C until it moves freely, or replace. Contact your Bradley representative and ask for Piston/Liner Kit (part number S65-180).

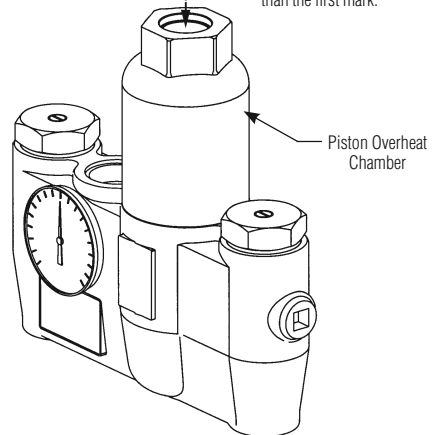

**Parts Breakdown**

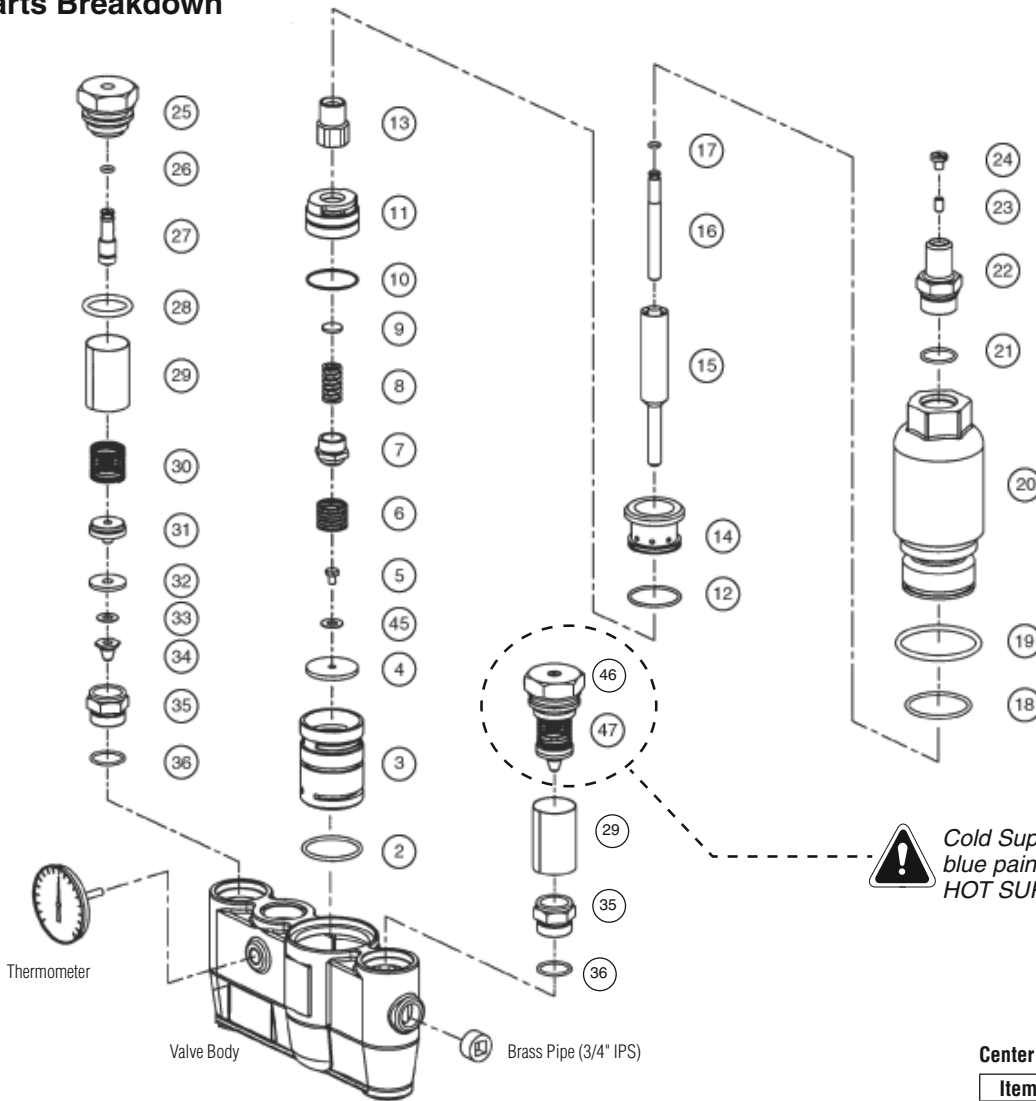

**!** Cold Supply Spring is marked with blue paint. DO NOT SWITCH WITH HOT SUPPLY SPRING (30).

**Thermostat Kit S65-178**

Item	Qty.	Description
15	1	Thermostat
17	1	O-Ring
21	1	O-Ring



Kit numbers for rough brass finish and standard range thermostat. Contact Bradley for other configurations.

**Piston & Liner Kit S65-180**

Item	Qty.	Description
2	1	O-Ring
3	1	Liner
4	1	Washer
5	1	Screw
6	1	Spring
7	1	Lower Overheat Chamber
8	1	Spring
9	1	Washer
10	1	O-Ring
11	1	Piston
12	1	O-Ring
13	1	Upper Overheat Chamber
14	1	Upper Seat
45	1	Washer

**Washer/Seal Kit S65-311**

Item	Qty.	Description
4	1	Washer
9	1	Washer
32	2	Seal
33	2	Washer
45	1	Washer

**O-Ring Kit S65-177**

Item	Qty.	Description
2	1	O-Ring
10	1	O-Ring
12	1	O-Ring
17	1	O-Ring
18	1	O-Ring
19	1	O-Ring
21	1	O-Ring
26	2	O-Ring
28	2	O-Ring
36	2	O-Ring

**Check/Stop Kit S65-359**

Item	Qty.	Description
25	2	Cap
26	2	O-Ring
27	2	Stem
28	2	O-Ring
29	2	Strainer
30	1	Hot Supply Spring
31	2	Holder (for Seal)
32	2	Seal
33	2	Washer
34	2	Nut
35	2	Seat
36	2	O-Ring
47	1	Cold Supply Spring (Blue)

**Center Section Kit S65-305**

Item	Qty.	Description
2	1	O-Ring
3	1	Liner
4	1	Washer
5	1	Screw
6	1	Spring
7	1	Lower Overheat Chamber
8	1	Spring
9	1	Washer
10	1	O-Ring
11	1	Piston
12	1	O-Ring
13	1	Upper Overheat Chamber
14	1	Upper Seat
15	1	Thermostat
16	1	Pushrod
17	1	O-Ring
18	1	O-Ring
19	1	O-Ring
20	1	Mixing Valve Cap
21	1	O-Ring
22	1	Control Cap
23	1	Set Screw
24	1	Screw
45	1	Washer