

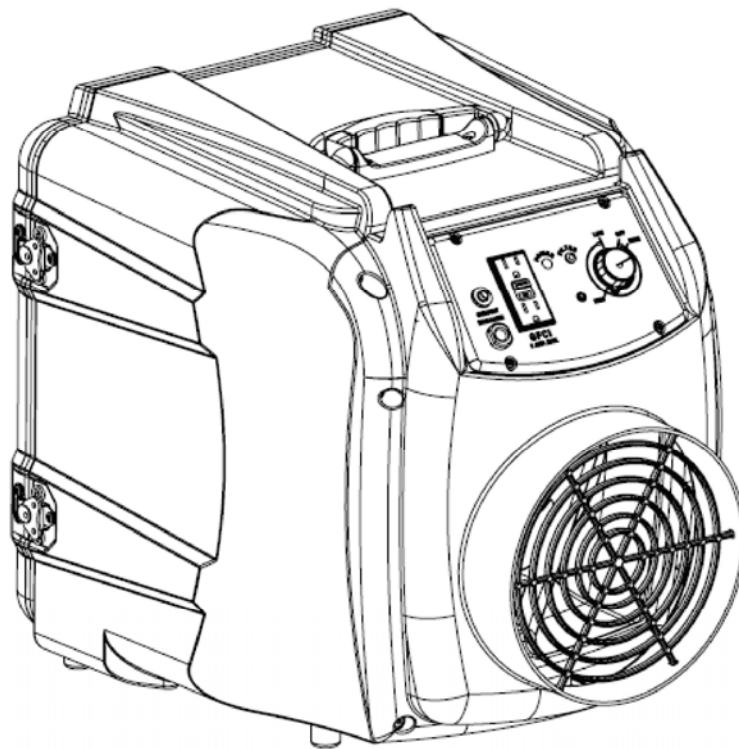

**PREDATOR[®] PORTABLE AIR SCRUBBER
MODEL PRED750**

INSTRUCTION MANUAL



Abatement Technologies, Inc.

**Abatement Technologies, Inc.
Georgia, USA
800-634-9091**

**Abatement Technologies, Ltd.
Ontario, Canada
905-871-4720**

www.abatement.com

KEY COMPONENTS

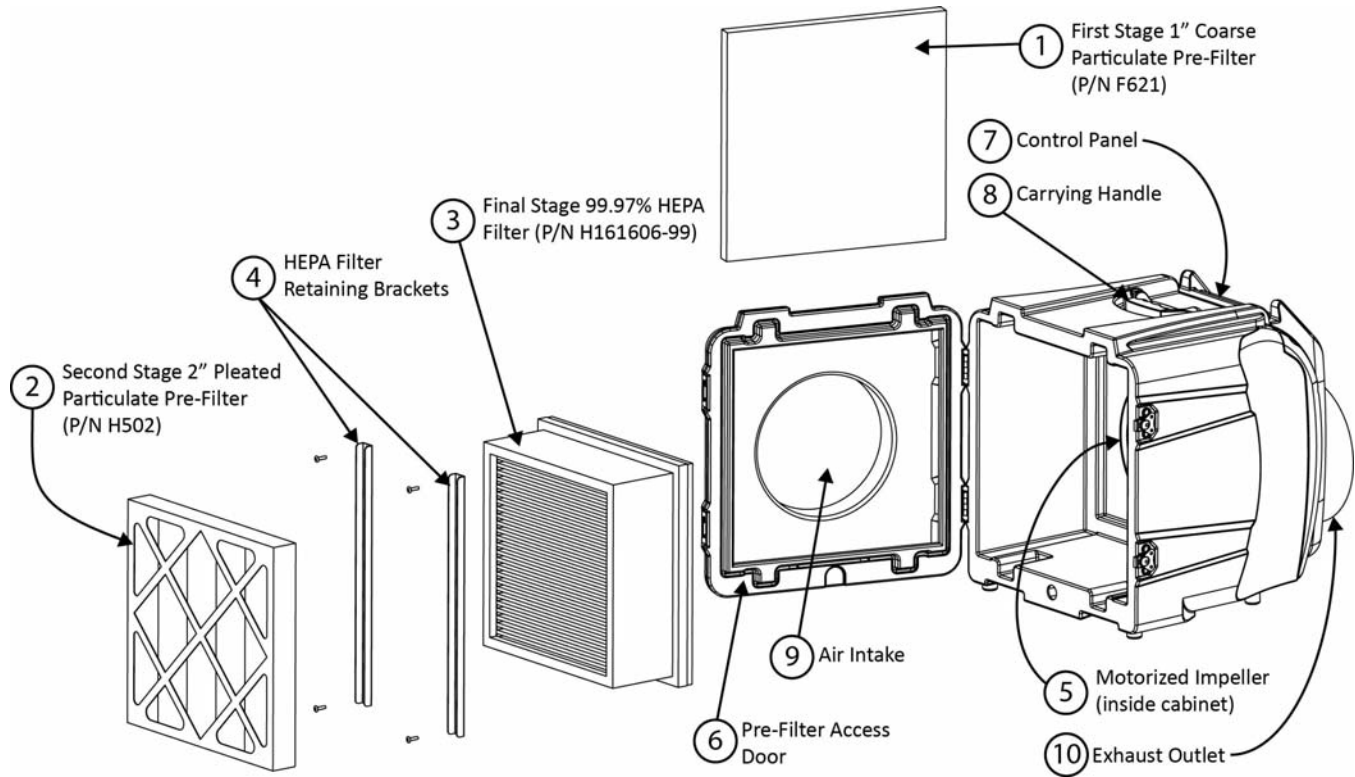

1. First Stage Filter: 1" Coarse Particulate Pre-filter (P/N F621)
2. Standard Second Stage Filter: 2" Pleated Pre-filter (P/N H502)
 - Alternate Second Stage Filter: 2" High Capacity Vapor-Lock[®] Carbon Filter (P/N VL1002)
3. Final Stage 99.97% HEPA Filter (P/N H161606-99)
4. HEPA Filter Retaining Brackets
5. Motorized Impeller (located inside cabinet)
6. Pre-filter Access Door
7. Control Panel
8. Carrying Handle
9. Air Intake - 10" nominal diameter
10. Exhaust Outlet - 10" nominal diameter

PREDATOR® Portable Air Scrubber
Model: PRED750
Instruction Manual

© Abatement Technologies 2015 All Rights Reserved. No reproduction of any portion of this work is permitted without the express written permission of Abatement Technologies, Inc.

READ AND SAVE THESE INSTRUCTIONS!

Note:

1. **Read and understand all operating instructions before using the Portable Air Scrubber.**
 2. **Save this manual for future reference.**
-

This instruction manual provides important information on the use of the Predator® Portable Air Scrubber, model PRED750. These instructions must be carefully followed in order to operate the unit safely and correctly. If there are any questions regarding the use of the unit, please contact Abatement Technologies immediately at 800-634-9091 U.S. or 905-871-4720 Canada.

Abatement Technologies strongly urges users of air filtration units and related accessories to follow the most recent guidelines and/or standards published by the Occupational Safety and Health Administration, Environmental Protection Agency, and all other federal, state, provincial and local regulations.

GENERAL INFORMATION

The PREDATOR® Portable Air Scrubber is a multi-use air filtration device, equipped with pre-filters and a HEPA filter that are capable of filtering many airborne contaminants. An alternate carbon pre-filter for capturing low concentrations of odors, vapors, gases, and volatile organic compounds, collectively known as OVG, is also available.

Types of contaminants captured by particulate pre-filters, HEPA filter, or carbon filters:

- | | | |
|----------------|---------------------------|--|
| • Dirt | • Lung-damaging particles | • Low concentrations of OVG |
| • Dust | • Metal fumes | • Low concentrations of Volatile Organic Compounds (VOC) |
| • Drywall dust | • Smoke | • Unpleasant nuisance odors |
| • Saw dust | • Mold and fungal spores | |

Note: To capture low concentrations of OVG, a Vapor-Lock® carbon filter must be used.

The PREDATOR® Portable Air Scrubber is capable of providing particulate and odor, vapor, gas filtration with final stage filtration through a High Efficiency Particulate Air (HEPA) filter. This unit incorporates a series of particulate filters that successively remove larger size to smaller size particles from the air. In addition to providing HEPA filtration, the PREDATOR® Portable Air Scrubber is primarily used in a negative pressure or recirculation mode. A negative pressure condition is created in order to confine contaminated airborne particles. This condition exists when the static pressure inside the room containing the unit is lower relative to the pressure of the environment outside the room. The static pressure differential is created and maintained by continuously exhausting air out of a given room at a faster rate than air enters the room from all other sources. In the recirculation mode, all of the filtered air is exhausted back into the room containing the unit.

STANDARD AIR CLEANING STAGES (FILTERS SUPPLIED WITH THE UNIT)

The PRED750 comes equipped with two progressively efficient pre-filters mounted in the pre-filter compartment, and a final stage HEPA filter, located inside the cabinet:

- The first-stage 1"-deep, coarse particulate pre-filter (F621) is designed to capture particles 100 microns or larger.
- The second-stage 2"-deep, particulate pleated pre-filter (H502) is designed to capture particles 10 microns or larger.
- Each HEPA filter (H161606-99) is tested & certified to capture at least 99.97% (9,997 out of 10,000) 0.3-micron particles.

Note: The particulate filters included with this unit do not remove odors, vapors or gases, including volatile organic compounds.

ALTERNATE SECOND STAGE FILTER: VAPOR-LOCK® CARBON FILTER (MUST BE PURCHASED SEPARATELY)

Vapor-Lock® pleated, high-capacity, carbon filters (part # VL1002) are available for capturing OVG. This 2"-deep filter can be used in place of the second-stage H502 pleated pre-filter to reduce airborne OVG by chemically bonding the OVG molecules to the surface area of the carbon granules, via a process known as adsorption. The VL1002 filter also provides a similar level of particulate filtration efficiency to the H502 pre-filter.

Effective carbon adsorption is dependent upon the amount of carbon & exposed carbon granule surfaces, and the dwell (contact) time the OVG molecules have with the carbon granules. Operating the unit at lower speed settings to increase dwell time can therefore improve OVG adsorption, though it is highly unlikely that all of the OVG will be removed in one pass of air through the unit. Operating the unit in the recirculation mode can increase effectiveness, by exposing OVG particles to multiple– passes through the Vapor-Lock filter.

It is almost impossible to provide accurate estimates to two commonly asked questions: “how much time will it take to capture all of the OVG?”, and “how do I know when a carbon filter should be replaced?” Unfortunately, unknown factors, such as concentration levels, fresh-air intake volume, temperature, and humidity prevent establishment of any more accurate ‘rule of thumb’ than one’s sense of smell. Since off-gassing of adsorbed OVG can occur when the adsorption capacity of the filter is reached, replace the carbon filter as soon as odor breakthrough is sensed. More detailed information on carbon adsorption can be found in an article titled: **“Activated Carbon: How Is It Used? How Does It Work?”** which can be found on the Abatement Technologies website, www.abatement.com.

HOW TO DETERMINE THE REQUIRED NUMBER OF AIR FILTRATION DEVICES (AFD)

Calculate the total air volume (V) in cubic feet (ft³) within the enclosed containment area by multiplying the length (L) x the width (W) x the height (H), all in feet ($V = L \times W \times H$).

Determine the minimum number of air changes per hour (ACH) specification. When no ACH number is specified, most users target at least 6 ACH for construction areas. Building in a safety factor to compensate for filter loading, duct losses, reduced voltage and other factors that can reduce actual installed airflow is a good practice. For example, if 6 ACH is the objective, you might design for 8 ACH.

Select an Abatement Technologies air filtration device (AFD) model and determine the peak airflow rating for that model in cubic feet per minute (CFM).

Determine the total number of AFD required using the following formula: $\text{Quantity} = (V \times \text{Design ACH}) / (\text{AFD Rating} \times 60)$

Always round up to the next whole number. For example, if the total number of AFD required is 2.13, 3 units are recommended, not 2.

Example: How many air filtration devices (each with 600 CFM rated airflow) would be required to provide 8 ACH (including a safety factor) in a 40ft L x 24ft W x 10ft H containment area?

1. $V = 40\text{ft} \times 24\text{ft} \times 10\text{ft} = 9,600\text{ft}^3$
2. Design ACH = 8
3. Quantity of AFD required = $(9,600\text{ft}^3 \times 8 \text{ ACH}) / (600 \text{ CFM} \times 60) = 76,800/36,000 = 2.13 = 3 \text{ units}$

ELECTRICAL REQUIREMENTS

1. The PREDATOR® Portable Air Scrubber requires a minimum of 110 volts AC, 60 Hz to operate properly; however, maximum airflow performance requires 120 volts AC, 60 Hz.
2. Due to momentary start-up current surge, the unit requires a 15 amp circuit that is free of other loads.
3. Extension cords used for this unit must be UL-listed, heavy duty No. 14/3 AWG SJTW industrial grade 3-wire type. Use of larger numerical gauge (lower capacity wire) power cord(s) may result in electrical shock, fire hazards and/or damage to unit. The cord(s) must be in good condition and in continuous lengths (no splicing) and should not exceed a total of 50 feet in length. Make certain that any extension cords used do not reduce power to the unit to less than 110 volts. Use of a voltmeter to confirm adequate voltage is recommended.
4. Check to ensure that any circuit to which the unit is connected is protected by a 15 ampere circuit breaker. The unit itself is equipped with a 12 amp circuit breaker.
5. This unit should be connected to a three-prong, properly grounded electrical outlet equipped with a Ground Fault Circuit Interrupt (GFCI) device. A GFCI is an electrical safety device that will trip the circuit and stop the flow of electricity if leakage of current is detected.
Important Note: The GFCI on this unit's control panel only detects leakage of current from the unit or an electrical device plugged into the GFCI. This unit should be plugged into a GFCI receptacle at the power source to protect the power cord and the unit. This GFCI will trip the circuit if it detects leakage of current from the power cord or unit.
6. To avoid personal injury, fire hazards and/or damage to the unit's electrical system and power cord, do not connect or disconnect the power cord to an electrical outlet unless the speed control switch is "OFF".

SAFETY INSTRUCTIONS

REQUIREMENTS FOR SAFE OPERATION

1. Never allow unauthorized individuals or children to operate the unit at any time.
2. Abatement Technologies urges anyone operating PREDATOR® air scrubber units to wear the proper personal protective equipment and follow safe work practices in accordance with federal, state, local, provincial and employer regulations.
3. Check the condition of power cord(s) before using them. Damaged cords can cause fatal electric shock and/or motorized impeller failure.
4. Power cord(s) should never be exposed to water, heat, and/or sharp or abrasive objects. In addition, they should never be kinked or crushed. Avoid tightly wrapping the cords to prevent kinking of the internal wires. Always replace damaged power cords immediately.
5. Never pull the unit by the power cord.
6. Avoid running over power cords with utility equipment and vehicles.

IMPORTANT SAFETY INSTRUCTIONS

- a. Do not operate any unit with a damaged cord or plug. Discard unit or return it to an authorized service facility for examination and/or repair.
- b. Do not run cord under carpeting. Do not cover cord with throw rugs, runners, or similar coverings. Do not route cord under furniture or appliances. Arrange cord away from traffic area and where it will not be tripped over.

Caution: As with any piece of electrical equipment, always make sure that the unit is turned “OFF” prior to connecting the power cord to an electrical outlet or disconnecting it from an electrical outlet. Failure to do so will cause “arcing”, and could result in personal injury, fire hazards and/or damage to the unit. Do not disconnect the power cord from supply receptacle while the unit is operating.

Warning: To reduce risk of electrical shock, do not expose this unit to water or rain. Do not touch the electrical outlet or power cord(s) with wet hands or while standing on a wet or damp surface.

Warning: Risk of electrical shock! Can cause injury or death! Turn unit “OFF” and disconnect power cord from supply receptacle before replacing the HEPA filter and before cleaning or servicing the unit.

Warning: This unit is equipped with an automatic restart motorized impeller that will restart without warning after a temporary power interruption or recovery from a thermal over- load (over-heating) condition. Keep clear of the motorized impeller at all times to reduce the risk of injury.

Warning: To reduce risk of fire or electrical shock, do not use this unit with any solid state speed control device. Do not use in a cooking area.

Caution: This unit is designed for indoor use only.

Caution: For General Ventilating Use Only. Do Not Use To Exhaust Hazardous Or Explosive Materials And Vapors.

Warning: Abatement Technologies air filtration systems are not intrinsically safe for use in hazardous environments. Always consult a certified industrial hygienist before using them. Do NOT use this equipment in any atmosphere that is or may be immediately dangerous to life or health (IDLH), combustible, flammable, explosive, oxygen deficient, and/or contains odors, vapors, gases or particulates that exceed permissible

exposure levels. Such atmospheres may require the use of intrinsically safe equipment, specific engineering controls, and personal protective equipment in accordance with Occupational Safety and Health Administration (OSHA), Environmental Protection Agency (EPA), Canadian Standards Association (CSA), and other federal, state, provincial and local regulations.

Warning: This equipment is not classified as “intrinsically safe” and should not be used in the following hazardous locations as defined by the Underwriters Laboratories: Class I Division 1, Class I Division 2, Class I Zone 0, Class I Zone 1, Class I Zone 2, Class II Division 1, Class II Division 2, Class III Division 1, Class III Division 2. Refer to http://en.wikipedia.org/wiki/Electrical_equipment_in_hazardous_areas

Warning: Do not use this unit near sparks, open flames or other possible sources of ignition.

OPERATING THE UNIT

IDENTIFYING KEY COMPONENTS OF THE CONTROL PANEL

1. **Power Cord** - Hardwired, 14/3 AWG SJTW power cord for connection to electrical outlet.
2. **Power Indicator** - Green light that indicates speed control switch is “ON” and system is connected to power source.
3. **Speed Control Switch** - Serves as the power switch and provides a variable adjustment to the speed of the motorized impeller.
4. **Filter Change Indicator** – Red light that indicates excessive restriction on intake or loading of the filter(s) and that filter change procedures should be followed. Check the Filter Change Indicator when the unit is operating at “HIGH” speed.
5. **Circuit Breaker** - 12 amp circuit breaker that provides protection for the unit’s electrical components.
6. **GFCI Receptacle** - Electrical safety device that will trip and stop the flow of electricity if leakage of current is detected from the unit or an electrical device plugged into the GFCI receptacle. The PRED750 can supply a total of 8 amps of electrical power for additional equipment that is connected to the GFCI receptacle. Do not exceed this 8 amp limit. **Note:** If the equipment connected to the GFCI receptacle draws more than a total of 8 amps, the circuit breaker on the control panel and/or the building breaker will trip. This condition can be remedied only by reducing the total amperage draw.

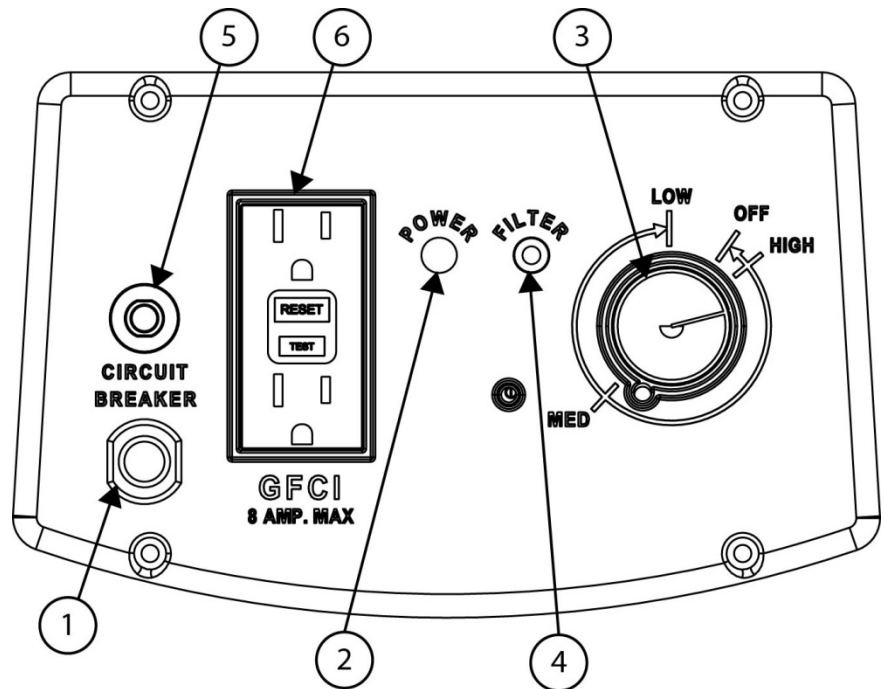

BEFORE OPERATING THE UNIT, NOTE THE FOLLOWING:

Inspect and tighten any HEPA filter retaining nuts that may have loosened during transportation. Inspect the filters for any material or structural damage prior to use and replace any damaged filters before operating the unit. When removing any filters prior to operation, always put them back in place with airflow indicator on filter housing oriented in the proper direction (if applicable).

Be sure to remove the foam plug from the inlet before use. Keep this foam plug so that the inlet can be plugged again after use to contain any debris that has been captured in the machine.

As with any air filtration system, external airflow losses not attributable to the air filtration unit will reduce the airflow of the system. The following recommendations can minimize airflow losses created by external static resistance.

1. Always use the minimum length of ducting possible with the fewest possible number of turns and bends.
2. Rigid metal ducting creates less turbulence and consequently less airflow loss than flexible ducting. Regardless of the type of ducting used, rigid, "sweep-type", radiused connections should be used for all turns and bends.
3. If flexible ducting is used, it must be kept as taut as possible to avoid flattening.

LOCATION OF THE UNITS AND MODES OF OPERATION

1. **Negative Pressure** - used to help ensure that airborne contaminants do not escape from a contained area, by maintaining negative (lower) air pressure within that area compared to adjacent areas. This is generally accomplished by placing the unit inside the containment area and exhausting filtered air from the unit out of the area. The filtered air must be exhausted outside of the containment area, either directly to the outdoors, or into another part of the building. To maintain negative pressure, the air exhaust must exceed the air supply by the greater of: 10% or 100 CFM. To achieve this differential, the air supply volume to the area may have to be reduced. Negative pressure levels should be continuously monitored.
2. **Recirculation** - used to reduce concentrations of airborne contaminants in a room or area by continuously cleaning the air and exhausting it back into the same room or area.
3. **Positive Pressure** - used to help prevent airborne contaminants from entering a containment area, by keeping that area under positive pressure compared to adjacent spaces, so any air leakage will be an outflow of clean air, and not inflow of contaminated air. This pressure differential can be established by:
 - a. placing the unit inside the containment area, and using it to pull air into the area by attaching flex duct between the inlet collar and a location outside of the containment area.
 - b. placing the unit outside of containment area, and using it to push HEPA-filtered air into the area through flex duct attached between the outlet collar and a location inside the area.

To ensure that the proper pressure differential is maintained, the volume of HEPA-filtered air supplied to the area must be the greater of: 10% or 100 CFM higher than the volume of air exhausted from it by the HVAC system. Positive pressure levels should be monitored continuously.

Important Note: Do not operate the unit unless the pre-filter(s) and HEPA filter are installed, and the filter access door and panel are in place and closed.

DAISY CHAINING

"Daisy Chaining" refers to the operation of multiple units on one circuit, with only one of the units plugged into a 120V/15A electrical power supply receptacle. Each subsequent unit is plugged into one of the GFCI receptacles on the prior unit, up to the maximum number allowed based on the amperage draw per unit. The National

Electrical Code (United States) limits the total amperage draw of devices operating on one circuit to 80% of full load, which means that the total amperage draw on a 120V/ 15A circuit, including the unit plugged into the building electrical power supply receptacle, must not exceed 12 amps. A total of five PRED750 units can be “Daisy Chained” on a 15 amp circuit, including the unit plugged into the building electrical power supply receptacle.

TO START UNIT

1. Check to make sure that the Speed Control Switch is in the “OFF” position. Plug power cord into a 120 volt AC, 60Hz, 15 amp supply circuit.
2. Turn Speed Control switch clockwise past the click at the “HIGH” setting to turn power “ON”.
3. Set Speed Control switch to desired setting.

Note: Refer to the chart in this instruction manual entitled "PRED750 SPECIFICATIONS" that lists the airflow range for the PRED750.

Note: In the event of a power failure while the unit is running, or loss of power due to any other cause, this unit’s motorized impeller will re-start when power is restored, after a brief delay.

FILTER CHANGE INDICATOR

Light “ON” indicates one or more of the following:

1. Loaded filter(s). Refer to filter change procedures.
2. Restrictions on air intake. Refer to Troubleshooting Guide.

STACKING THE UNITS

The PRED750 Portable Air Scrubber units can be stacked up to 3 units high total. The bottom of the unit is designed to nest into the top of another PRED750 unit. Since the filters are accessed through a hinged door, the filters can be changed while in the stacked configuration. It is not recommended to stack more than 3 units high due to safety as well as the compounding weight of the units.

STORAGE AND TRANSPORT OF THE UNIT

TRANSPORTING THE UNIT

The PREDATOR® Portable Air Scrubber should be transported in its normal position (resting on its rubber feet). If extremely poor road conditions exist, or excessive shock and vibration are expected, take precautionary measures by padding the unit to provide impact absorption during transport.

The units can be stacked up to 3 units high total for transporting purposes. However, the stacked units must be secured in such a way as to prevent the units from falling.

Caution: Always use caution when moving the PREDATOR® Portable Air Scrubber inside a building or home. The unit weighs 35 pounds. Older structures with weakened floors or staircases may require special considerations for safe transport.

FOAM INLET PLUG

The PREDATOR® Portable Air Scrubber comes with a foam plug that fits into the inlet of the unit. Be sure to remove the foam inlet plug before use and insert it back into the inlet after use. The foam plug keeps any collected contaminants that are caught in the filters or inside the cabinet from escaping the unit when the unit is not in use.

CORD WRAP

The PRED750 has a built-in cord wrap for storing the power cord when not in use. It is important that the cord is wrapped to help protect the cord from damage during transport and storage. Wrap the cord as shown in the picture below and secure the plug head to the cord using the integrated clip.

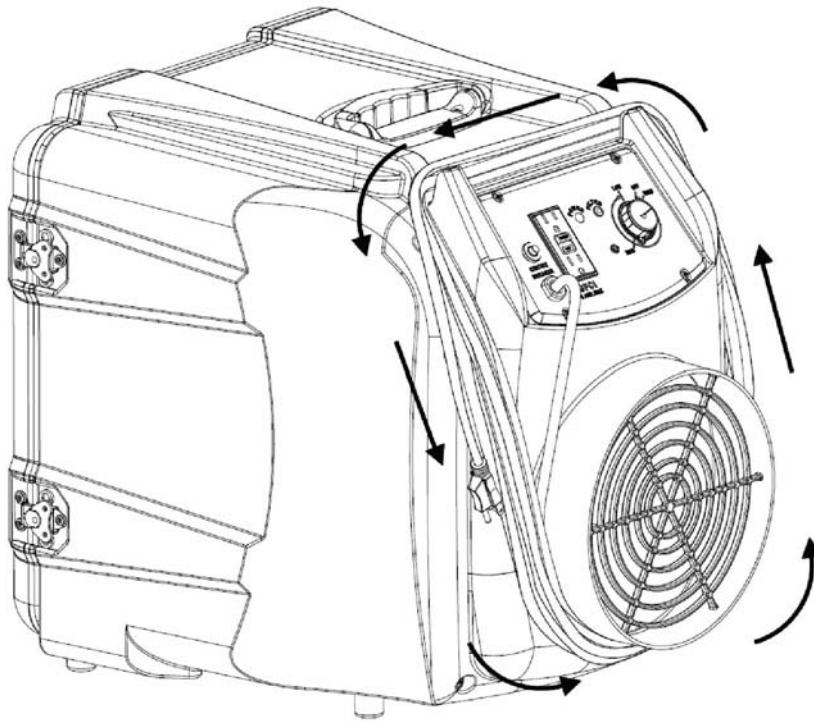

USER SERVICING INSTRUCTIONS

Abatement Technologies' portable air scrubbers are designed to be low maintenance devices and basic maintenance should be performed as follows:

- Filters should be changed as needed based on the filter change indicator light. Follow the FILTER CHANGE PROCEDURE as described in this manual. Filters can be changed earlier, if desired, to maintain a minimum required flow rate.
- The unit should be cleaned with a damp cloth or a water-based cleaner/sanitizer as needed. Do not use harsh chemicals, solvents or detergents to clean the unit. **Warning: Keep electrical components dry as their exposure to liquids poses a safety hazard and can damage components.**
- Test the GFCI located on the unit's control panel on a monthly basis to ensure proper operation.
 1. Plug the unit in and verify that the GFCI on the control panel is receiving power by ensuring the green light in the corner of the GFCI is illuminated.
 2. Depress the "TEST" button until you hear a click; the green light on the GFCI should turn off.
 3. Depress the "RESET" button on the GFCI until you hear a click; the green light on the GFCI should turn on.

FILTER REPLACEMENT

Note: Personnel responsible for changing filters, servicing units or relocating units within the facility are urged to wear the proper personal protective equipment (PPE) and follow safe work practices in accordance with federal, state, provincial, local and employer regulations. Abatement Technologies cannot recommend the type of PPE required as that will need to be determined by safety/risk assessment personnel based on various risk factors, including the type of particulates being captured by the air filtration device and the surrounding environment where the units are being used, transported, or serviced.

Note: Filters being replaced must be disposed of in accordance with federal, state, provincial, local and facility regulations.

System airflow reduction is generally the result of filter loading, blockage of the unit's inlet or use of excessive lengths of flex duct that is connected to the inlet.

The size and concentration of airborne contaminants, temperature and humidity conditions, and duration of use determine how often filters need replacement. If the Filter Change Indicator on the control panel illuminates, this indicates one or more of the following: (1) filter(s) are loaded, (2) the inlet is obstructed, and (3) the flex duct, if attached to inlet, is too long or has too many bends.

The method of determining when to replace an activated carbon filter is somewhat subjective. As the odor, vapor, and/or gas filtration capacity decreases, the user will begin to sense a slight odor or taste of the contaminant, indicating that the filter should be replaced.

Note: The filters are not reusable, therefore, do not attempt to clean and reuse them.

Caution: Abatement Technologies PREDATOR® Portable Air Scrubber units are designed to meet or exceed standards for high efficiency air filtration equipment. Use only Abatement Technologies parts, including replacement filters. Use of non-Abatement Technologies parts and filters voids the product warranty and all performance claims.

Warning: To reduce the risk of fire, electrical shock or personal injury, always turn the unit "OFF" and disconnect the power cord from supply receptacle before replacing the HEPA filter and before cleaning or servicing the unit.

FILTER CHANGE PROCEDURE

To Change the First Stage Filter:

1. With the unit operating, turn the two latches on the pre-filter access door counterclockwise (approx ½ turn), swing the latches outward, and open the door. Remove the first-stage filter located inside the door itself and replace it with a new one.
2. Close the door and lock it in position by swinging the latches inward and turning the latch clockwise. Make sure the door is flush against the unit's cabinet before closing the latch.
3. If the Filter Change Indicator light remains "ON" after changing the first-stage filter, the second-stage filter should be replaced.

To Change the Second Stage Filter:

1. Open the pre-filter access door by turning the two latches counterclockwise (approximately 1/2 turn), swing the latches outward, and open the door.
2. Remove the second-stage pleated filter and replace it with a new one. The pleats on the air filter should be oriented so that they are vertical and the air flow directional arrow on the filter should point toward the control panel.

Note: If an alternate VAPOR-LOCK® filter is being used, be sure to remove it from its poly bag before installing it in the unit. VAPOR-LOCK® filters are packaged in poly bags to preserve the integrity of the carbon granules.

3. Close the door and lock it in position by swinging the latches inward and turning the latch clockwise. Make sure the door is flush against the unit's cabinet before closing the latch.
4. If the Filter Change Indicator light remains "ON" after changing the second-stage filter, the HEPA filter should be replaced.

To Change the HEPA Filter:

1. Turn the unit "OFF" and disconnect the unit's power cord from the electrical outlet.
2. Open the pre-filter access door by turning the two latches counterclockwise (approximately $\frac{1}{2}$ turn), swing the latches outward, and open the door.
3. Remove the second-stage pleated filter. The HEPA filter is located behind the pleated pre-filter.
4. The HEPA filter is held into place by two metal brackets. Remove the two screws from each bracket and then remove the HEPA filter from the machine.
5. Insert the new HEPA filter with the pleats oriented vertically and the air flow directional arrow on the filter pointing towards the control panel (the gasketed side of the HEPA filter will be against the internal wall).

Note: The HEPA filter is delicate and should be handled with care. When removing or reattaching the HEPA filter retaining brackets, do not touch the filter media; otherwise, damage to the filter and leakage of contaminated air could result.

6. Replace the two metal brackets and secure the brackets with the screws.
Important: Do not use a power screw driver or drill to tighten the screws down as this may strip the screw head; tighten with a manual screw driver only.
7. Insert the second-stage pleated filter into the machine. The pleats on the air filter should be oriented so that they are vertical and the air flow directional arrow on the filter should point toward the control panel.
8. Close the door and lock it in position by swinging the latches inward and turning the latch clockwise. Make sure the door is flush against the unit's cabinet before closing the latch.

Note: The HEPA filter is not designed to be cleaned and using methods such as compressed air in an attempt to clean the filter can cause damage to the filter and comprise the HEPA filter efficiency rating.

Warning: Use only Abatement Technologies pre-filters, HEPA filters, and replacement parts. Substitute parts void the warranty, jeopardize worker and environmental safety, and adversely affect engineered performance levels.

PRED750 SPECIFICATIONS

FEATURE	SPECIFICATION
Net weight with filters:	35 lbs.
Shipping weight:	43 lbs.
Unit dimensions:	19.5"W x 25.5"L x 20.5"H
Shipping carton dimensions:	20"W x 29"L x 21.5"H
Power supply requirements:	110-120V, 60Hz, single phase, 15 amp circuit
Normal operating amps:	1.9 amps or less
Integrated circuit breaker:	12 amps
Motorized impeller:	258 watt motorized impeller with thermal overload protection, auto reset, 60Hz, single phase
Operating flow rate: (with clean filters)	Variable speed , air flow range from 200CFM to 750CFM.
Operational sound level:	65 dBA on max speed, reading taken at 5'.
Operating ambient temperature range:	34°F to 104°F
Cabinet:	Rotational-molded high density polyethylene cabinet. Contains EPA registered additive for inhibiting microbial growth and UV-8 additive rated for 8,000 hours of protection against UV deterioration.
Transportability:	Heavy duty flip-up style transport handle
Stackability:	Units are stackable and can stack up to 3 units high.
Daisy chaining:	GFCI outlet on control panel allows daisy chaining. Up to (5) PRED750 units can be daisy chained together, including the unit that is plugged into the building receptacle.
Pre-filter access:	Hinged "no tools" pre-filter access door with turn and latch closure and neoprene gasket.
First stage pre-filter:	1" deep coarse particulate pre-filter (Part Number F621).
Second stage pre-filter:	2" deep pleated particulate pre-filter (Part Number H502).
Alternate second stage pre-filter:	2" deep high capacity carbon filter for odors (Part Number VL1002).
HEPA filter:	HEPA mini-pleat filter with continuous seamless gasket, tested and certified to an efficiency of 99.97% or higher against 0.3 micron size particles (Part Number H161606-99).
Inlet & Outlet	Integrated 10" nominal diameter inlet and outlet.

Note: Specifications subject to change without notice.

Note: Airflow rating estimates are based on factory and independent testing at 120VAC, 60Hz with an air straightener and a traverse of readings taken with a computing vane-anemometer. Actual results may vary for various reasons, including motor and blower and HEPA filter tolerances. Factors such as filter loading, reduced voltage to the motor, and inlet and outlet ducting will reduce airflow. Use the ratings as a general guideline only.

TROUBLESHOOTING GUIDE

PROBLEM	POSSIBLE CAUSE	SOLUTION
No response when the power is turned on	Power cord unplugged. Defective power cord. Tripped circuit breaker. Tripped ground fault circuit interrupter. Thermal overload on the motorized impeller has tripped.	Plug power cord firmly into electrical outlet in wall. Check all connections and condition of cords. Do not operate with damaged power cord(s). Reset breaker for building. Reset 12 amp breaker on control panel. Reset GFCI on control panel and/or at power source. Turn unit "OFF", wait 30 minutes and restart unit.
Circuit breaker on control panel or building "trips".	Overloaded circuit.	Unplug any additional equipment connected to the GFCI receptacle. Reset circuit breaker. Restart unit on "High" speed.
Filter change indicator is "ON".	Loaded filters. Excessive restrictions on intake. Carbon filter has not been removed from polybag.	Change in accordance with operating instructions. Reduce bends, length of flex duct, or eliminate restrictions. Remove carbon filter from polybag.

Note: If the unit does not start or malfunctions after carefully following the TROUBLESHOOTING GUIDE, call Abatement Technologies service department at 800-634-9091 (U.S.) or 905-871-4720 (Canada) for assistance.

COMPONENT REPLACEMENT

Warning: To reduce the risk of fire, electrical shock or personal injury, always turn the unit "OFF" and disconnect power cord from supply receptacle before removing the control panel, replacing the HEPA filter and before cleaning or servicing the unit. This unit is equipped with an automatic restart motorized impeller that will restart without warning after a temporary power interruption or recovery from a thermal overload (over-heating) condition. Keep clear of the motorized impeller at all times to reduce the risk of injury.

Occasionally a defective component will cause the unit to operate improperly or not at all. Any electrical component can fail. Refer to the Wiring Diagrams and Wiring Schematics to diagnose the failure of any component. Diagnostics should only be performed by a technician qualified to service electrical equipment.

CERTIFICATION OF ROOM AIR FILTRATION UNITS

The Abatement Technologies room air filtration units have been tested by Intertek Testing Services (ITS) and are ETL and ETLC (Canada) listed for electrical safety.

ITS is accredited by the U.S. Occupational Safety and Health Administration (OSHA) as a Nationally Recognized Testing Laboratory (NRTL).

LIMITED WARRANTY

Abatement Technologies, Inc (ATI) warrants that goods sold to the original user shall be free from defects in material and workmanship for a period of 1 year, except such as are commercially acceptable. This warranty does not include useful filter life. ATI does not warrant that the goods sold are merchantable or fit for any particular purpose. ATI makes no warranties other than as stated in this paragraph. All other warranties, guaranties, or representations, express or implied, by operation of law or otherwise, are expressly disclaimed. **Goods found by ATI to be defective or not to conform to specification shall upon return be replaced or repaired by ATI without any additional charges, or, at ATI's option, ATI may refund the purchase price of such goods. ATI will pay return transportation charges on returned goods not exceeding the transportation charges applicable to shipment from original destination unless the returned goods are free from defect and conform to specifications. Returned goods which are found by ATI to be free from defect and to conform to specifications shall be held for Purchaser's shipping instructions, which instructions Purchaser shall furnish promptly upon request.** ATI's liability shall in no event extend beyond replacement, repair or refund of the purchase price and ATI shall not be liable under any circumstances for special, contingent or consequential damages, nor for loss, damages, or expenses directly or indirectly arising from the use of the goods, including without limitation, warehousing, labor, handling and service charges, die, equipment, or machine breakage, nor for costs, lost profits or loss of good will. The use of substitute, non-ATI parts and/or filters, in any ATI product, voids all warranties and performance claims. The remedies set forth herein are exclusive.

For warranty information and assistance contact Abatement Technologies' Customer Service Department at 800-634-9091 (U.S.) or 905-871-4720 (Canada.)

Abatement Technologies' PRED750 high-efficiency air filtration units are originally equipped with true HEPA (High Efficiency Particulate Air) filters designed to maximize the performance of the equipment, and to meet the following industry standards:

Institute of Environment Sciences and Technology

IEST-RP-CC001.4 (Type A HEPA and ULPA Filters)

IEST-RP-CC021.2 (Testing HEPA and ULPA Filter Media)

Underwriters Laboratories

UL900

100% Efficiency Tested

Abatement Technologies HEPA filters are individually tested and certified to ensure that the completed filter provides an overall minimum efficiency of 99.97% when challenged by a thermally generated test aerosol, 0.3-microns in size, in accordance with IEST-RP-CC034.2.

PRED750 WIRING DIAGRAM

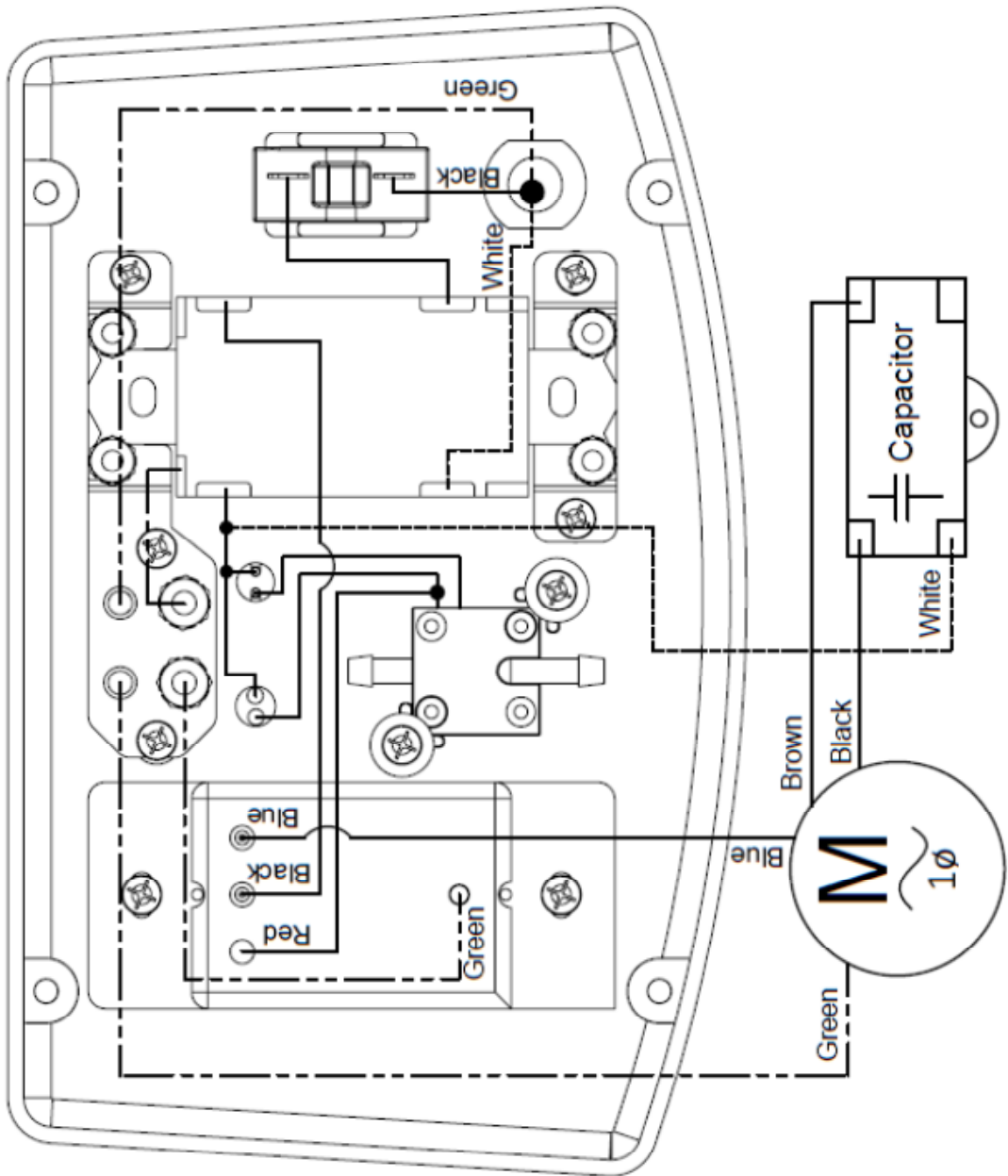

PRED750 WIRING SCHEMATIC

